



FILTER UNITS MINI I

Technical Features:

- Seal less vertical pump
- IN/OUT Tank installation
- Lid fast locking system by PP nut or bolts
- Cartridge tightening independant from cylinder length
- Vent valve
- PP and PVDF version
- Tmax exercise 75°C – 95°C PVDF

Advantages:

- Practical
- Versatile
- Rugged construction
- Space Saver
- Drive run capability



FILTER UNITS MINI N

Technical Features:

- Single phase magnetic drive pump
- Cartridge tightening independant from cylinder length
- Lid fast locking system by PP nut
- Vent valve
- Switch, cable and plug included with pump motor
- Tmax exercise 60°C

Advantages:

- Practical
- Versatile
- Economical
- Space Saver

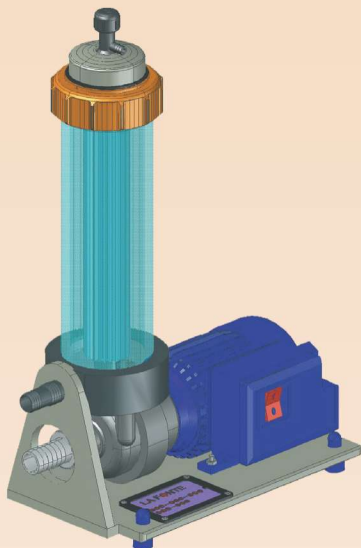

model MINI N

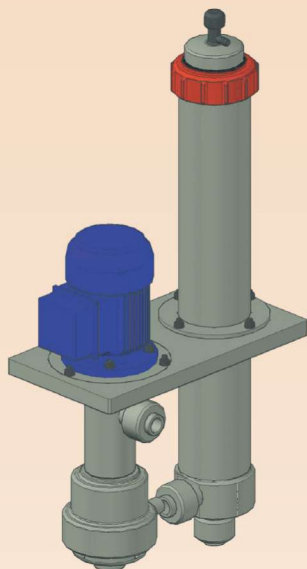

model MINI I - P

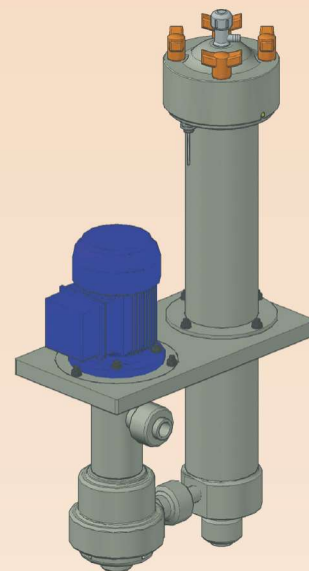

model MINI I - G

FILTER UNIT MINI I							
Mod	FILTER CHAMBER			SERIES	PUMP		OPTIONAL
	MATERIAL	CARTRIDGE H"	VERSION		VERTICAL	MATERIAL	TYPE
MINI	_ =PP V=PVDF	10	P=Plus	I	EYP3N	_ =PP V=PVDF	I=interlock sensor (only on G version)
		20	G=Golden		EYP8N		G=pressure gauge with guard
		30			EYP10N		
MINI	V	20	G	I	EYP8N	V	G

FILTER UNIT MINI N						
Mod	FILTER CHAMBER		SERIES	PUMP		OPTIONAL
	MATERIAL	CARTRIDGE H"		MAGNETIC	MATERIAL	TYPE
MINI	_ =Plexiglass	4	N	MPC042	_ =PP V=PVDF	
		10				
MINI		10	N	42		

	MPC042	EYP3N	EYP8N	EYP10N
Qmax (l/h)	1800	3000	6500	9600
KW	0,12	0,15	0,37	0,7
A (230/1V)	0,9			
A* (230/400V)		0,77/0,44	1,80/1,00	3,13/1,7

* data can change according with motor brand

— MPC042 — EYP8NP
— EYP3N — EYP10N

